



## Assessing the Validity and Reliability of a Measurement Model in Structural Equation Modeling (SEM)

Sabri Ahmad<sup>1</sup>, Nazleen Nur Ain Zulkurnain<sup>1\*</sup> and Fatin Izzati Khairushalimi<sup>1</sup>

<sup>1</sup>University Malaysia Terengganu, 21030 Kuala Terengganu, Terengganu, Malaysia.

### Authors' contributions

This work was carried out in collaboration between all authors. Author SA designed the study, wrote the protocol and supervised the work. Authors NNAZ and FIK carried out all laboratories work and performed the statistical analysis. Author NNAZ managed the analyses of the study. Author SA wrote the first draft of the manuscript. Author FIK managed the literature searches and edited the manuscript. All authors read and approved the final manuscript.

### Article Information

DOI: 10.9734/BJMCS/2016/25183

#### Editor(s):

(1) Raducanu Razvan, Department of Applied Mathematics, Al. I. Cuza University, Romania.

#### Reviewers:

(1) Gehan Dhameeth, Wells College, USA.

(2) Shudong Wang, NWEA, USA.

Complete Peer review History: <http://sciencedomain.org/review-history/13806>

Received: 22<sup>nd</sup> February 2016

Accepted: 8<sup>th</sup> March 2016

Published: 22<sup>nd</sup> March 2016

Short Research Article

## Abstract

**Aims:** To assess the validity and reliability of a measurement model in structural equation modeling (SEM).

**Study Design:** Short research article.

**Place and Duration of Study:** UiTM Kota Bharu Campus and International Islamic University Malaysia Kuantan Campus, between September and October 2014.

**Methodology:** A survey methodology using simple random sampling was carried out, covering the 220 students. A structured questionnaire was then distributed to 220 students. Then, the confirmatory factor analysis in structural equation modeling was employed to assess the validity and reliability of a measurement model.

**Results:** The results implied that the validity and reliability of the measurement model achieved the required level.

**Conclusion:** Based on this study, it revealed that all the fitness indexes achieved the level of acceptance. The validity and reliability of the measurement model was achieved. The measurement model is valid and reliable. It can be assembled into the structural model for further analysis.

\*Corresponding author: E-mail: [nazleennurain@gmail.com](mailto:nazleennurain@gmail.com);

*Keywords: Structural Equation Modeling (SEM); Confirmatory Factor Analysis (CFA); validity; reliability; measurement model.*

## 1 Introduction

Structural Equation Modeling (SEM) is a comprehensive statistical approach to testing hypothesis about relations among observed and latent variables [1].

Structural Equation Modeling (SEM) is a confirmatory method giving a comprehensive means for assessing and modifying the measurement models as well as a structural model. The method has the ability to assess the unidimensionality, validity and reliability of a measurement model [2].

This paper applies entrepreneurial intention as a research subject to be test for assessing the validity and reliability of a measurement model. In particular, this paper has four variables namely Attitude Toward Behavior (ATB), Subjective Norm (SN), Perceived Behavioral Control (PBC) and Entrepreneurial Intention (EI).

## 2 Methodology

The target population was the university students from UiTM Kota Bharu Campus and International Islamic University Malaysia Kuantan Campus. A total of 220 students were involved in this study. When there is five or less latent construct and each latent construct has more than three measuring items, the minimum sample required is 100 samples [3]. This study used primary sources of data since the data or information for this study originally collected through questionnaire.

The data was analyzed by Structural Equation Modeling (SEM) using AMOS 21.0 software. SEM is a multivariate technique, which estimates a series of inter-related dependence relationships simultaneously. The hypothesized model can be tested statistically in a simultaneous analysis of the entire system of variables to determine the extent to which it is consistent with the data.

There is several Fitness Indexes in SEM that reflect how fit is the model to the data. It is recommended that the use of at least one fitness index from each category of model fit [4]. The information concerning the model fit category, their level of acceptance and literature are presented in Table 1.

**Table 1. Fitness indexes**

<b>Name of category</b>	<b>Name of index</b>	<b>Index name</b>	<b>Level of acceptance</b>	<b>Literature</b>
Absolute Fit	Chisq	Discrepancy chi square	$P > 0.05$	[5]
	RMSEA	Root Mean Square of Error Approximation	$< 0.08$	[6]
Incremental Fit	GFI	Goodness of Fit Index	$> 0.90$	[7]
	AGFI	Adjusted Goodness of Fit	$> 0.90$	[8]
	CFI	Comparative Fit Index	$> 0.90$	[9]
	TLI	Tucker-Lewis Index	$> 0.90$	[10]
Parsimonious Fit	NFI	Normed Fit Index	$> 0.90$	[11]
	Chisq/df	Chi Square/Degree of freedom	$< 5.0$	[12]

Validity is the ability of instrument to measure what it supposed to be measured for a construct [2]. The validity of measurement model is assessed based on the requirements stated in Table 2. There are three types of validity required for each measurement model:

**Table 2. Validity**

Validity	Requirements
Convergent validity	The convergent validity is achieved when all items in a measurement model are statistically significant. This validity could also be verified through Average Variance Extracted (AVE). The value of AVE should be greater or equal to 0.5 in order to achieve this validity.
Construct validity	The construct validity is achieved when the Fitness Indexes achieve the level of acceptance. (Refer to Table 1).
Discriminant validity	The discriminant validity is achieved when the measurement model is free from redundant items. Another requirement for discriminant validity is the correlation between each pair of latent exogenous construct should be less than 0.85. Other than that, the square root of AVE for the construct should be higher than the correlation between the respective constructs [2].

Reliability is the extent of how reliable is the said measurement model in measuring the intended latent constructs [2]. The reliability of measurement model are assessed based on the criteria stated in Table 3. There are three criteria for the assessment of reliability for a measurement model:

**Table 3. Reliability**

Reliability	Criteria
Internal reliability	Internal reliability is achieved when the Cronbach's Alpha value is 0.6 or higher
Construct reliability	The measure of reliability and internal consistency of the measured variables representing a latent construct. In order to achieve the construct reliability, a value of $CR \geq 0.6$ is required.
Average variance Extracted	Average Variance Extracted (AVE) is the average percentage of variation explained by the items in a construct. An $AVE \geq 0.5$ is required.

The formula to calculate the value of Construct Reliability (CR) and Average Variance Extracted (AVE) are shown in the Table 4 below.

**Table 4. Formula**

	Formula	Notes
CR	$(\sum \kappa)^2 / [(\sum \kappa)^2 + (\sum 1 - \kappa^2)]$	K = factor loading of every item n = number of itmes in a model
AVE	$\sum \kappa^2 / n$	

### 3 Results and Discussion

#### 3.1 Descriptive analysis

Table 5 shows that the frequency for gender. Out of 220 respondent, there are 49 male and 171 female.

**Table 5. Gender**

Gender	Frequency	Percentage (%)
Male	49	22.3
Female	171	77.7
Total	220	100

**Table 6. Program**

Program	Frequency	Percentage (%)
Statistic	108	49.1
Bio Medic	112	50.9
Total	220	100

Table 6 shows that the program enrolled by the respondents. There are 108 respondents from the statistic field and 112 respondents from the bio medic field. So the totals are 220 respondents.

### 3.2 Confirmatory Factor Analysis (CFA): Measurement model

Confirmatory Factor Analysis (CFA) is a special form of factor analysis. It is employed to test whether the measure of a construct are consistent with the researcher’s understanding of the nature of that construct. Fig. 1 shows that the measurement model combining all construct.

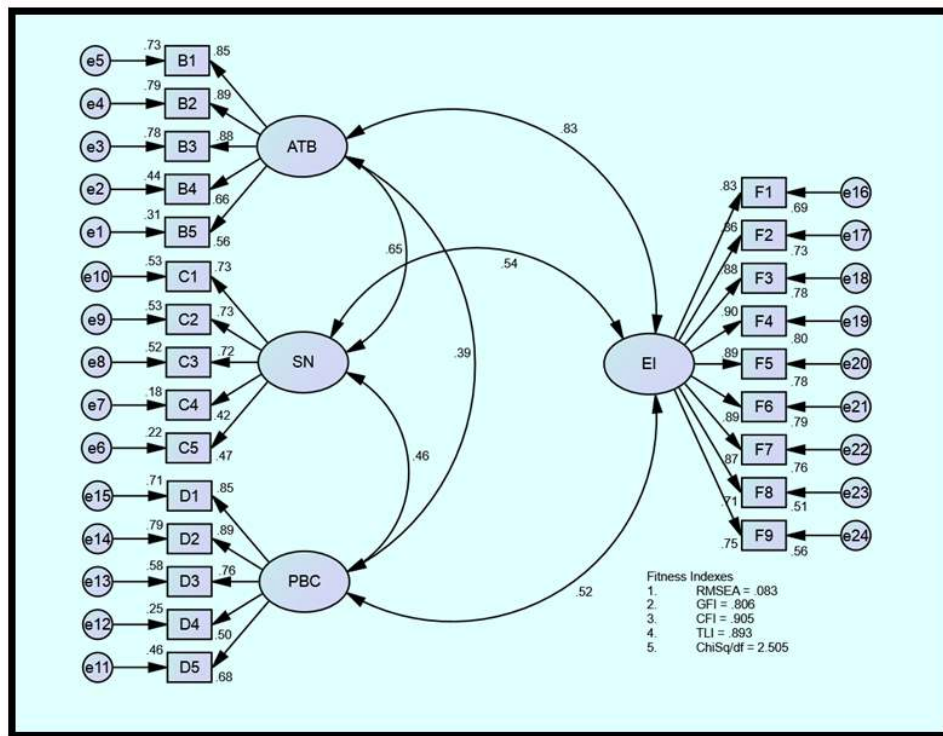

**Fig. 1. Measurement model**

Source; ATB: Attitude Toward Behavior, SN: Subjective Norm, PBC: Perceived Behavioral Control, EI: Entrepreneurial Intention

Fig. 1 shows that the result of measurement model after running the confirmatory factor analysis. The items that have factor loading below 0.60 should be deleted. This measurement model need to be re-specify because the value of Fitness Indexes does not achieved the required level.

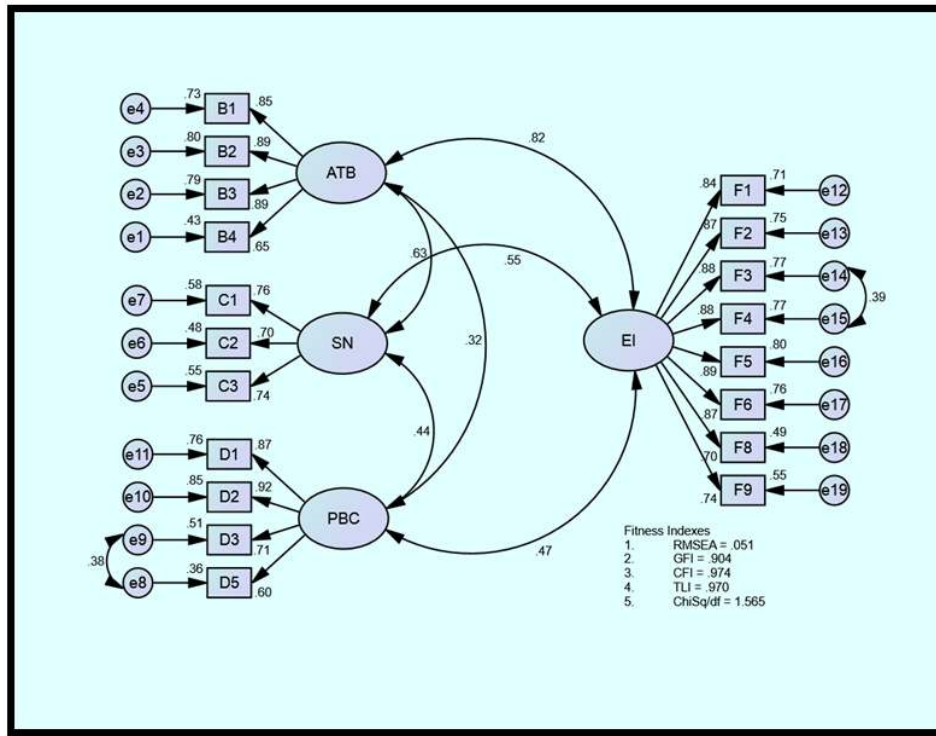

**Fig. 2. Last measurement model**

Source; ATB: Attitude Toward Behavior, SN: Subjective Norm, PBC: Perceived Behavioral Control, EI: Entrepreneurial Intention

Fig. 2 shows that the last measurement model after deleted the item with low factor loading below 0.6. Item B5, C4,C5,D4 are deleted due to low factor loading. Item F7 is deleted because the item is redundant. Item D3 and D5 and item F3 and F4 are redundant so there are set to be “free parameter estimate”.

There is several Fitness Indexes that reflect how fit is the model to the data at hand. All value of fitness indexes for the model have achieved the level of acceptance. The summary of fitness indexes for the model are assessed in Table 7.

**Table 7. Summary for fitness indexes**

Name of category	Name of index	Index value	Comments
Absolute fit	RMSEA	0.051	Achieved the required level
	GFI	0.904	Achieved the required level
Incremental fit	CFI	0.974	Achieved the required level
	TLI	0.970	Achieved the required level
Parsimonious fit	Chisq/df	1.565	Achieved the required level

Table 8 shows that the summary of confirmatory factor analysis (CFA) for all constructs in the last measurement model.

From Table 8, the value of factor loading for all item are greater than 0.6. Other than that, the value of Cronbach Alpha for all constructs are greater than 0.60.

**Table 8. Summary for all constructs**

Construct	Item	Factor loading	Cronbach alpha	CR	AVE
Attitude Toward Behavior (ATB)	B1	0.85	0.888	0.887	0.665
	B2	0.89			
	B3	0.89			
	B4	0.65			
Subjective Norm (SN)	C1	0.76	0.771	0.778	0.538
	C2	0.70			
	C3	0.74			
Perceived Behavioral Control (PBC)	D1	0.87	0.870	0.862	0.617
	D2	0.92			
	D3	0.71			
	D5	0.60			
Entrepreneurial Intention (EI)	F1	0.84	0.948	0.949	0.800
	F2	0.87			
	F3	0.88			
	F4	0.88			
	F5	0.89			
	F6	0.87			
	F8	0.70			
	F9	0.74			

### 3.3 Validity and reliability

The results for validity assessment of measurement model are presented in the Table 9 below.

**Table 9. Validity result**

Validity	Results
Convergent validity	All items in a measurement model are statistically significant. Other than that, the value of AVE for all construct is greater than 0.50. The Convergent Validity was achieved the required level.
Construct validity	From the last measurement model, all fitness indexes meet the required level. The construct validity was achieved the required level.
Discriminant validity	From the last measurement model, the redundant items are constrained as “free parameter”, also the correlation between all constructs are lower than 0.85.

*Source; AVE: Average Variance Extracted*

Table 10 shows that the diagonal values in bold are the square root of AVE for the construct while other values are the correlation between the respective constructs. The discriminant validity is achieved when the diagonal value in bold is higher than the values in its row and column. From Table 10, all the diagonal value in bold is higher than the values in its row and column, therefore the discriminant validity was achieved.

**Table 10. Discriminant validity**

Construct	ATB	SN	PBC	EI
ATB	<b>0.82</b>			
SN	0.63	<b>0.73</b>		
PBC	0.32	0.44	<b>0.79</b>	
EI	0.82	0.55	0.47	<b>0.89</b>

*Source; ATB: Attitude Toward Behavior, SN: Subjective Norm, PBC: Perceived Behavioral Control, EI: Entrepreneurial Intention*

The results for reliability assessment of measurement model are presented in the Table 11 below.

**Table 11. Reliability result**

<b>Reliability</b>	<b>Criteria</b>
Internal reliability	The value of Cronbach Alpha is greater than 0.60. The internal reliability was achieved the required level. (Refer Table 8)
Construct reliability	The value of CR for all constructs are greater than 0.60. The composite reliability was achieved the required level. (Refer Table 8)
Average variance extracted	The value of AVE for all constructs are greater than 0.50. The required level was achieved. (Refer Table 8)

*Source; AVE: Average Variance Extracted, CR: Composite Reliability*

## 4 Conclusion

The main purpose of this study is to assess the validity and reliability of a measurement model using structural equation modeling. We can conclude that the measurement model has achieved their validity and reliability. The Convergent Validity was achieved through the value of AVE which is higher than 0.50 [13]. Since that the value of Fitness Indexes for measurement model achieved the level of acceptance, therefore the Construct Validity achieved the required level. The correlation between all constructs should be lower than 0.85. Here, the discriminant validity was satisfied the required level since that the correlation between all constructs in the measurement model are less than 0.85. Other than that, the discriminant validity also achieved when the diagonal values in bold which are the square root of AVE for the construct are higher than the values of correlation between the respective constructs.

The value of Cronbach Alpha for all construct in the measurement model are greater than 0.6 [14]. Therefore, the Internal Reliability was achieved the required level. The Composite Reliability was achieved through the value of CR greater than 0.6 [13]. Lastly, the Average Variance Extracted should be greater than 0.5 in order to meet the required level. The value of AVE for this measurement model are higher than 0.5. The last measurement model is valid and reliable. This measurement model can be assembled into structural model for further analysis.

## Competing Interests

Authors have declared that no competing interests exist.

## References

- [1] Abdullah Azhar, Annum Javaid, Mohsin Rehman and Asma Hyder. Entrepreneurial intentions among business students in Pakistan. *Journal of Business Systems, Governance and Ethics*. 2010;5(2):13-21.
- [2] Zainudin A. SEM made simple: A gentle approach to learning structural equation modeling. MPWS Rich Publication Sdn. Bhd; 2015.
- [3] Hair JF, Black WC, Babin BJ, Anderson RE. *Multivariate data analysis*. 7<sup>th</sup> ed. Englewood Cliffs, NJ: Prentice Hall; 2010.
- [4] Holmes-Smith P, Cooze L, Cunningham E. *Structural equation modeling: From the fundamental to advanced topics*. Melbourne: Streams; 2006.

- [5] Wheaton B. Assessment of fit in overidentified models with latent variables. *Sociological Methods and Research*. 1987;16:118–154.
- [6] Browne MW, Cudeck R. Alternative ways of assessing model fit. In Bollen KA, Long JS, (Eds.). *Testing Structural Equation Models*. Newbury Park, CA: Sage; 1993.
- [7] Joreskog KG, Sorbom D. LISREL-VI user's guide. 3<sup>rd</sup> ed. Mooresville, IN: Scientific Software; 1984.
- [8] Tanaka JS, Huba GJ. A fit index for covariance structure models under arbitrary GLS estimation. *British Journal of Mathematical and Statistical Psychology*. 1985;38:197-201.
- [9] Bentler PM. Comparatives fit indexes in structural models. *Psychological Bulletin*. 1990;107:238-246.
- [10] Bentler PM, Bonett DG. Significance tests and goodness of fit in the analysis of covariances structures. *Psychological Bulletin*. 1980;88:588-606.
- [11] Bollen KA. A new incremental fit index for general structural equation models. *Sociological Methods and Research*. 1989b;17:303-316.
- [12] Marsh HW, Hocevar D. Application Of confirmatory factor analysis to the study of self-concept: first- and higher-order factor models and their invariance across groups. *Psychological Bulletin*. 1985;97:562–582.
- [13] Fornell C, Larcker DF. Evaluating structural equations models with unobservable variables and measurement error. *Journal of marketing Research*. 1981;18:39-50.
- [14] Nunnally JC, Bernstein IH. *Psychometric theory*. 3<sup>rd</sup> ed. New York: McGraw-Hill; 1994.

---

© 2016 Ahmad et al.; This is an Open Access article distributed under the terms of the Creative Commons Attribution License (<http://creativecommons.org/licenses/by/4.0>), which permits unrestricted use, distribution, and reproduction in any medium, provided the original work is properly cited.

**Peer-review history:**

The peer review history for this paper can be accessed here (Please copy paste the total link in your browser address bar)

<http://sciencedomain.org/review-history/13806>